

SC 020/7

SCARRABILE CON SFILLO E RIBALTAMENTO

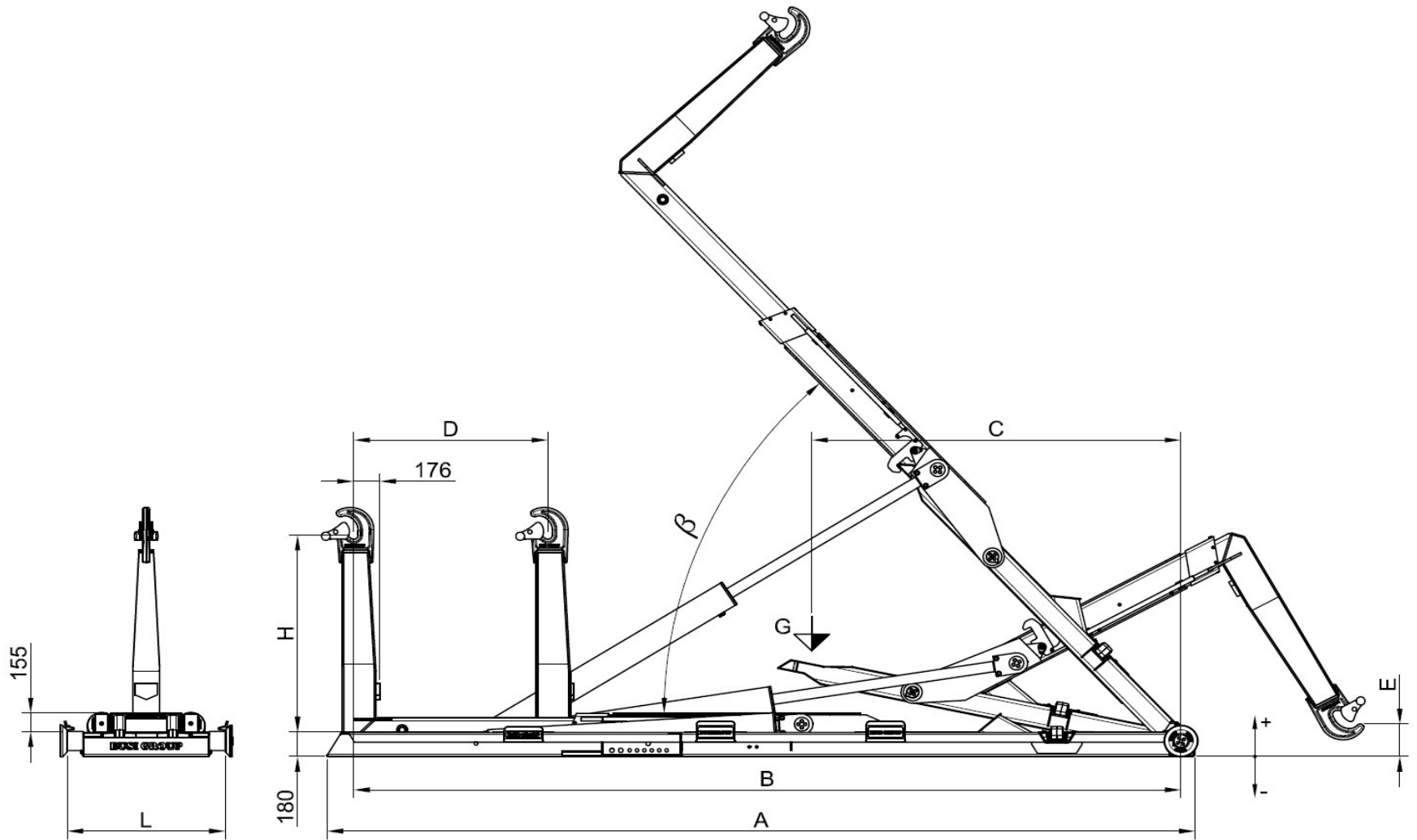

Modèle Equip	PTAC Minimum conseillée	Poids Equip	Angle	Debit conseillée de la pompe	Pression Max	Capacité maximale de charge	Dimensions							Caisson conseillé	
Equipment Model	Minimum GVW recommended	Equip Weight	Angle	Recomm. pump flow	Max Pressure	Maximum loading capacity	Dimensions							Recommended container	
Modello Scarrabile	PTT Minimo consigliato	Peso Scarr.	Angolo	Portata consigliata della pompa	Pressione Max	Capacità massima di carico	Dimensioni							Cassa consigliata	
	TON	Kg	β	Litri / min	Bar	TON	A	B	C	D	H	E	L	MIN	MAX
SC 020 / 58	26	2260	53°	60	340	20	6075	5800	3240	1115	1430 / 1570	-10 / -150	1070	4800	6400
SC 020 / 60	26	2270	53°	60	340	20	6275	6000	3280	1315	1430 / 1570	-10 / -150	1070	4800	6600
SC 020 / 62	26	2310	53°	60	340	20	6475	6200	3340	1315	1430 / 1570	10 / -130	1070	5000	6800
SC 020 / 64	26	2320	53°	60	340	20	6675	6400	3380	1515	1430 / 1570	10 / -130	1070	5000	7000